

REV.	DESCRIPTION	ECN NO.	NAME	DATE
1	NEW FRAME	N/A	HYH	2020-08-27

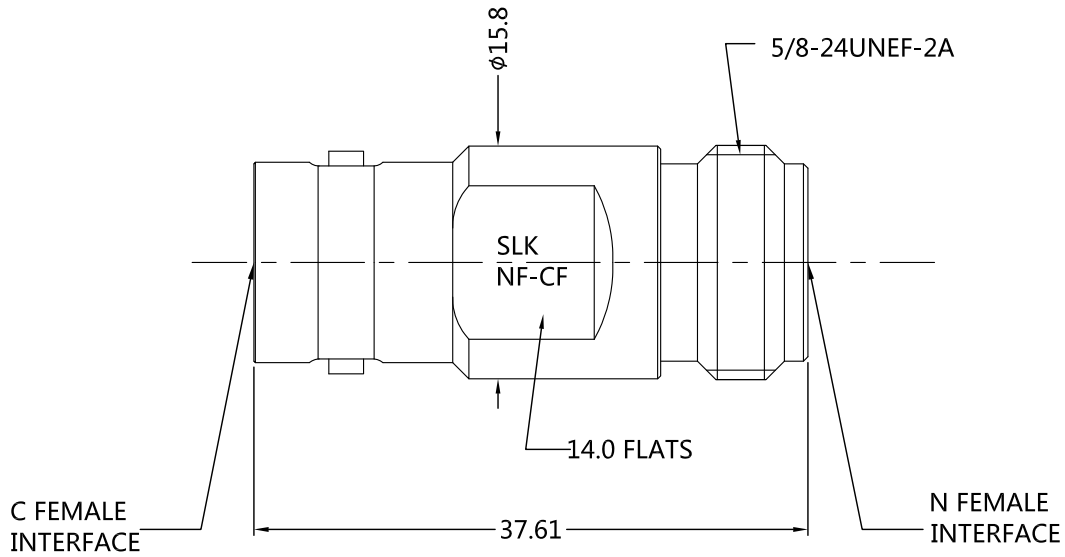

ALL PARTS MUST MEET TO RoHS REQUIREMENTS



MATERIALS AND PLATING		UNIT: MICRO-INCHES
PART NAME	MATERIALS	PLATING
BODY	BRASS C3604	NICKEL PL.100u"/COPPER
CONTACT PIN	BE-CU C17300	GOLD PL.30u"/NICKEL/COPPER
INSULATOR	PTFE ASTM-D-1710	N/A

ELECTRICAL CHARACTERISTICS	
IMPEDANCE	50 Ω
VOLTAGE RATING	500 V(rms)
FREQUENCY RANGE	0 ~ 10 GHz
DIELECTRIC WITHSTANDING VOLTAGE	>1000 V
CONTACT RESISTANCE	CENTER CONTACT <math>< 3.0 \text{ m}\Omega</math>
	OUTER CONTACT <math>< 2.0 \text{ m}\Omega</math>
INSULATION RESISTANCE	>5000 M Ω
INSERTION LOSS	<math>< 0.05X\sqrt{F(\text{GHz})} \text{ dB}</math>
RETURN LOSS	N/A
VSWR	<1.20
3RD INTERMODULATION	N/A

MECHANICAL CHARACTERISTICS	
FORCE TO ENGAGE AND DISENGAGE	N/A
CENTER CONTACT RETENTION FORCE	>6 lbs
RECOMMENDED COUPLING TORQUE	N/A
CABLE RETENTION FORCE	N/A
DURABILITY	>500 cycles

ENVIRONMENTAL PARAMETER	
TEMPERATURE RANGE	-55 $^{\circ}\text{C}$ ~ +125 $^{\circ}\text{C}$

*** CUSTOMER OUTLINE DRAWING**

UNLESS OTHERWISE SPECIFIED:

- 1) EDGES : C0.15 MAX ;
- 2) REMOVE ALL BURRS ;
- 3) SURFACE ROUGHNESS : Ra1.6 ;
- 4) UNITS : mm ;
- 5) DIMENSIONS TOLERANCES
 DECIMALS : .x ± 0.3 .xx ± 0.2 .xxx ± 0.1 ;
 ANGLES : $\pm 5^{\circ}$.

THIRD ANGLE PROJECTION

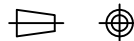

APPROVED :

CUSTOMER P/N :

CHECKED :

SCALE :

1 : 1

DRAWING :

HYH

DATE : 2020-08-27

PAGE : 1/1



TITLE : N FEMALE TO C FEMALE ADAPTER,50 Ω

DRAWING NO. :

5NCF06S-CCF

COMPANY WEBSITE : www.slkcorp.com

CUSTOMER OUTLINE DRAWING